

MODULAR PRE-ENGINEERED BRIDGE SYSTEMS

For Permanent, Emergency and Temporary Applications

Alok Bhowmick, FNAE

International Professional Engineer (India)

Past President, IAStructE

Managing Director, B&S Engineering Consultants Pvt. Ltd.



**International
Conference on**
**New Technologies
and Innovations
in Rural Roads**
24-26 May 2022
Pragati Maidan, New Delhi, India



Ministry of Rural Development
Government of India



**Pradhan Mantri
Gram Sadak Yojana**

MODULAR PRE-ENGINEERED BRIDGE SYSTEMS

For Permanent, Emergency and Temporary Applications



CONTENTS :

1. INTRODUCTION

2. SYSTEM DETAILS & BRIDGE COMPONENTS

3. MANUFACTURING – Fabrication & Quality Control

4. CONCLUSION

MODULAR PRE-ENGINEERED BRIDGE SYSTEMS

For Permanent, Emergency and Temporary Applications



CONTENTS :

1. INTRODUCTION

2. SYSTEM DETAILS & BRIDGE COMPONENTS

3. MANUFACTURING – Fabrication & Quality Control

4. CONCLUSION

Modular Pre-Engineered Steel Bridges – Definition

- **Modular bridges are pre-fabricated in modules that can be installed quickly in the field without the aid of any heavy equipment. It is built in a controlled environment typically in a factory environment and then installed at the site.**
- **Being modular, it is easy to construct and install. It has major advantages in speed of execution and flexibility. The various components remain small and light enough to be carried in the ordinary truck and lifted and erected at the site manually without the use of a crane. The bridges are also strong enough to carry vehicular loads that normally ply the road.**

INTRODUCTION



Utility of Modular Bridges to function as :

- **Temporary Bridges:** These bridges are often installed as a temporary structure during construction and then disassembled and stored until used again as a temporary structure.
- **Emergency Bridges:** These systems could be utilized in a time of national emergency. Natural disasters can destroy a bridge by washout or collapse. Typical prefabricated bridges can be erected much faster than the time of constructing a cast-in-place structure.
- **Permanent Bridges:** Use of prefabricated steel bridges as permanent bridges is cost-effective and desirable in many situations.

INTRODUCTION

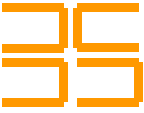

APPLICATION OF MODULAR BRIDGES



**Permanent Bridge
Sonprayag Bridge-Uttarakhand
(Post-Disaster 2013 Floods)**



Temporary Bridges



Emergency Bridges

Temporary vs. Permanent

Globally, panel bridges are often used in permanent applications due to their safety, robustness, modularity and ease of installation.

It's important that the designer provides realistic specifications to ensure the bridge will perform as anticipated.

Considerations for Permanent Bridge Applications

- Design Life – 75 to 100 years
- Design Vehicle (Current and Future)
 - Permit or Special Vehicles
 - Average Daily Truck Traffic (Design Vehicle)
- Pedestrian and Utility Loads
- Fatigue Requirements
- Overlay Type
- Deflection Requirements
- Environmental Loads

INTRODUCTION



APPLICATION OF MODULAR BRIDGES



**Emergency Modular Bridge in
New Delhi during Common
Wealth Games 2010**

INTRODUCTION



HISTORY OF MODULAR BRIDGES

- The modern-day prefabricated Panel/Floor Beam/Deck system was first patented by A.M. Hamilton in 1935.
- The bridge was used for a quick mobilization to allow military access to remote locations or to replace destroyed bridges in times of conflict.
- This system is currently known as the Callender-Hamilton System.
- This design was augmented by Sir Donald Bailey in the 1940s and is the predecessor to what became the most popular system, known as "The Bailey Bridge".



INTRODUCTION

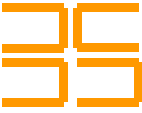

HISTORY OF MODULAR BRIDGES

British Engineer, Sir Donald Coleman Bailey further improved on Hamilton's design and adapted a methodology that he patented in 1943. This became popular worldwide. The uniqueness of this system is as follows:

- Was Pre-Engineered & Modular & interchangeable
- Could be delivered on-site in standard trucks
- Individual components can be carried by 6 men or less
- Would require minimum equipment to build
- Could be erected quickly. No welding used.
- Could support trucks and heavy vehicular traffic

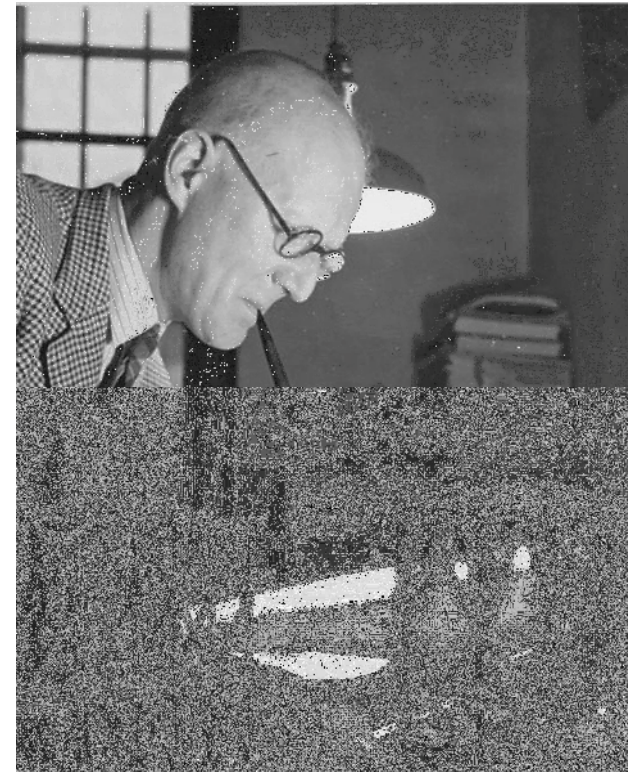

Sir Donald Coleman Bailey
(1901-1985)

INTRODUCTION

HISTORY OF MODULAR BRIDGES



INTRODUCTION

HISTORY OF MODULAR BRIDGES

Post World War II (1940's thru 1960's)

- Bailey Bridges continued to be manufactured & used for emergency situations.
- In India, 1st / 2nd Generation Modular Bridges (Bailey Bridges & Hamilton Bridges) are manufactured and used even now.
- Miles of WWII vintage Bailey Bridges became available to many governments as “Army Surplus”.
- Concepts of pre-engineered bridge systems and accelerated bridge construction are still to be developed



INTRODUCTION

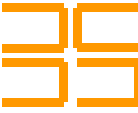

HISTORY OF MODULAR BRIDGES

1960's and 1970's

- **Modular Panel bridges find their niche in Emergency Bridges.**
- **Due to their pre-engineered modular design, panel bridges allowed for a quick replacement of damaged structures.**
- **Developing countries also created an additional demand for a pre-engineered bridge system that could be shipped in standard 20 ft. and 40 ft. containers**



HISTORY OF MODULAR BRIDGES

1970's to Present

- Design of the Modular Panel Bridges evolve.
- Systems improve modularity to maximize the utilization of components.
- Higher strength (S450) steels are now used which increased the strength to weight ratio yielding longer clear spans.
- Painted Bridges are replaced by galvanization to increase service life, reduce maintenance costs, and protect the environment.
- Multi-lane bridges are developed with Modular concept.



INTRODUCTION



SUMMARY : The specific advantages of modular bridges are: (1/2)

- **Rapid availability**
- **Lightweight constituent parts**
- **Light inherent weight due to high-strength steel**
- **Easy transportation of the modules**
- **Short construction time**
- **High-strength bolts means no on-site welding**
- **Do not require high level of skill for assembly and erection.**
- **Various structural systems can be used (single-span, continuous beam)**

INTRODUCTION



SUMMARY : The specific advantages of modular bridges are: (2/2)

- **Suitable for all types of traffic (including multi-lane) and railways.**
- **Standardized, compact and interchangeable components**
- **Long-term durability due to low material fatigue construction**
- **Optimum protection against corrosion through hot galvanization**
- **Low service and maintenance costs**
- **Simple, low maintenance, replaceable elastomer supports**

MODULAR PRE-ENGINEERED BRIDGE SYSTEMS

For Permanent, Emergency and Temporary Applications



CONTENTS :

1. INTRODUCTION

2. SYSTEM DETAILS & BRIDGE COMPONENTS

3. MANUFACTURING – Fabrication & Quality Control

4. CONCLUSION

SYSTEM DETAILS & BRIDGE COMPONENTS

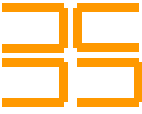

PROPRIETARY MODULAR BRIDGE SYSTEMS AVAILABLE:

1. Callender-Hamilton Bridge System
2. The Bailey Bridge System
3. The Acrow Bridge System
4. The Mabey Johnson Bridge System
5. The Janson Bridge System
6. The Quadricon Bridge System
7. MBS – BERD Modular Bridge Solutions
8. Many more



SYSTEM DETAILS & BRIDGE COMPONENTS



CALENDAR-HAMILTON GIRDER BRIDGE SYSTEM

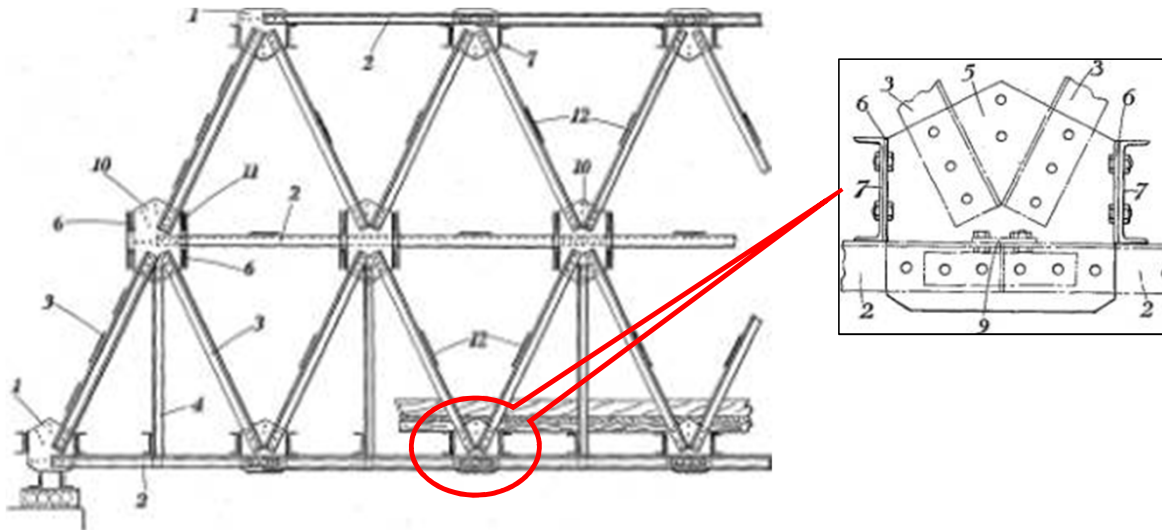

These girders are of warren type truss with double intersection for web member for spans ranging from 60' to 150'. These are designed for purpose of building long spans (above 24.4m) as rapidly as possible in case of emergency

The design was centered on a series of gusset plates that allowed the direct attachment of the longitudinal, diagonal, vertical, and cross framing members.

Northern Railway is in possession of these bridges in their stock, which is often needed for Emergency Situations

SYSTEM DETAILS & BRIDGE COMPONENTS

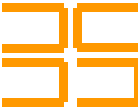

BAILEY BRIDGE SYSTEM

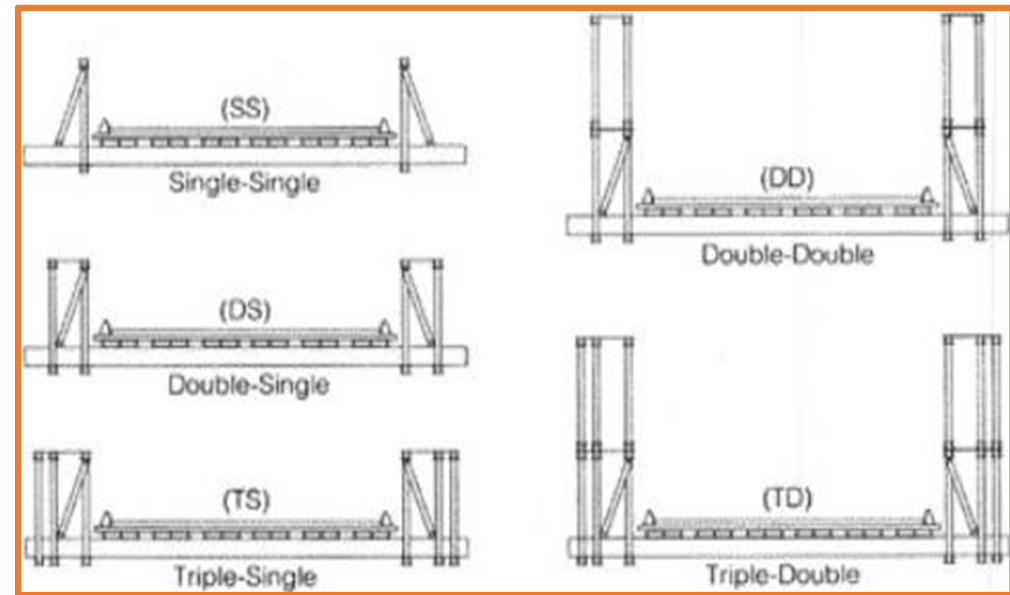
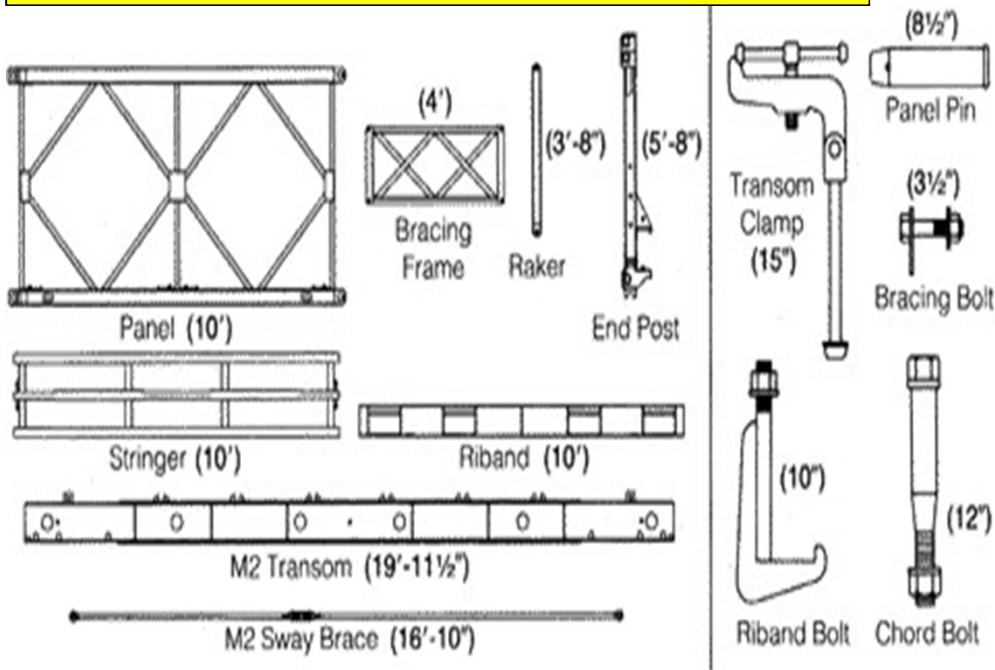

Main load-bearing side truss girders built from prefabricated, modular, rectangular panels (10 feet long and 4 feet 9 inches high center to center of pin-hole connections). The panels are pinned or bolted end-to-end at their top and bottom chords.

M/s GRSE, M/S Bridge and Roof and M/s Titagarh Wagon Ltd are manufacturers in India.

SYSTEM DETAILS & BRIDGE COMPONENTS



ACROW BRIDGE SYSTEM

- Pre-Engineered, modular and manufactured
- Can support vehicle & train loadings in excess of 250 tonnes
- Steel orthotropic deck units
- Galvanized finish
- Designed to the local bridge codes
- Single Spans up to 80m
- Multi-Span Bridges
- Suitable for seismic regions
- Used for permanent, temporary & emergency applications
- No field welding or fabrication
- Rapidly deployed and erected using MHE or by hand
- Versatility that allows for assembly in any length or width and load combination
- Can be delivered in standard ISO shipping containers for delivery worldwide
- Local transport using 6 m lorries

SYSTEM DETAILS & BRIDGE COMPONENTS



ACROW BRIDGE SYSTEM

Given the modularity of the ACROW system, once the carriageway width, bridge span, and design loading cases are known, an optimum bridge configuration can be determined.

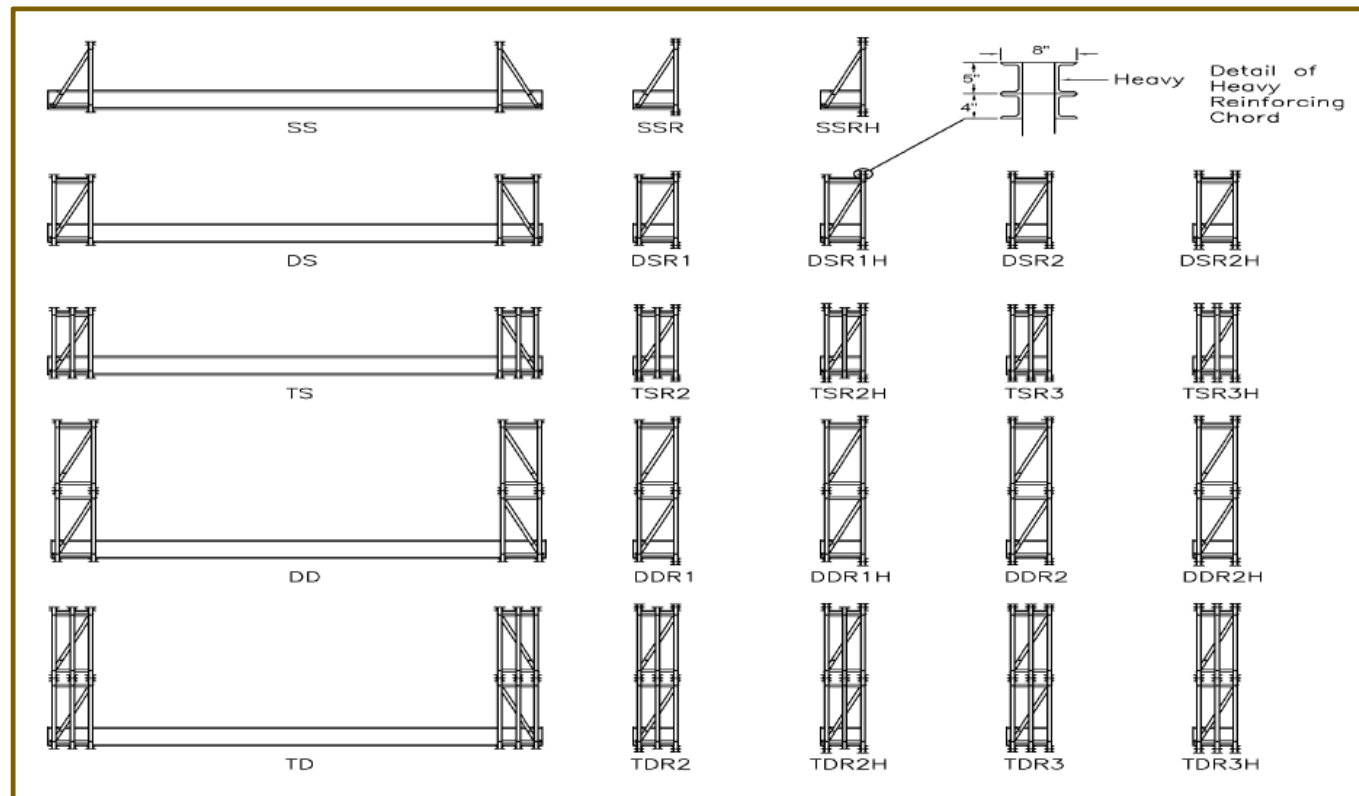

SYSTEM DETAILS & BRIDGE COMPONENTS



TYPICAL BRIDGE COMPONENTS :

1. Deck
2. Transoms
3. Truss Panels

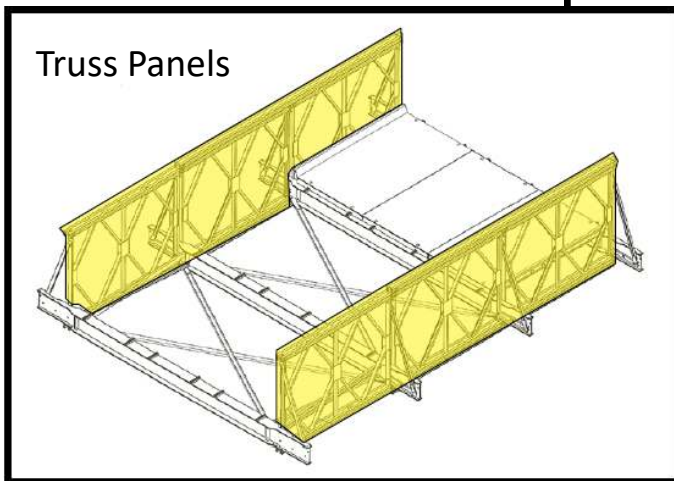
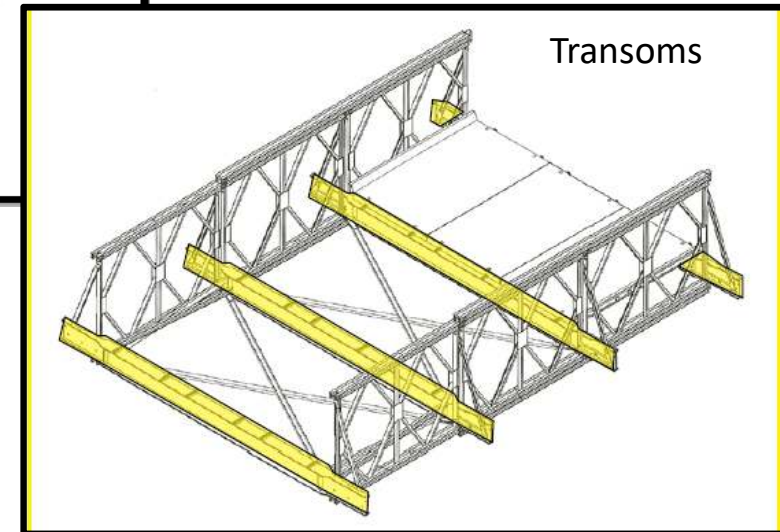
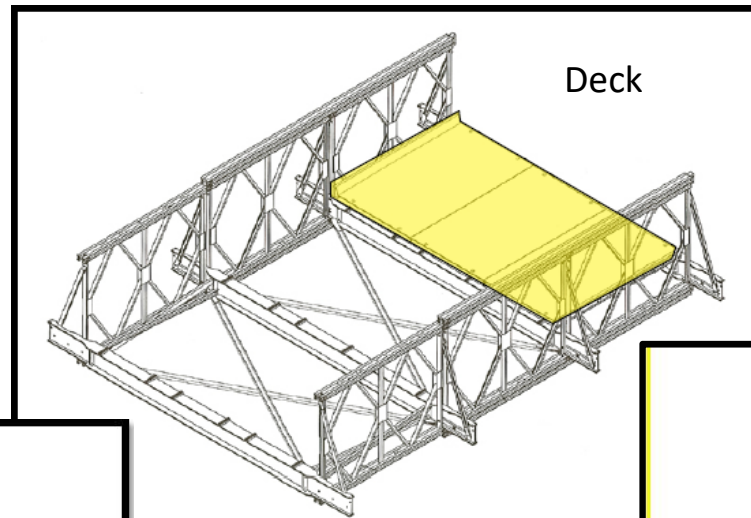

MODULAR PRE-ENGINEERED BRIDGE SYSTEMS

For Permanent, Emergency and Temporary Applications



CONTENTS :

1. MODULAR BRIDGES – History, Advantages & Application
2. SYSTEM DETAILS & BRIDGE COMPONENTS
3. MANUFACTURING – Fabrication & Quality Control
4. CONCLUSION

MANUFACTURE RATHER THAN FABRICATION

Unlike traditional steel bridge construction, panel bridging is manufactured rather than fabricated thereby allowing the greater use of automation.

Using automation, the end user receives a modern and high-quality product with little or no defects that need to be addressed on site during the build.



MANUFACTURING – Fabrication & Quality Control



DESIRABLE QUALITY CONTROL PROCESS FOR MANUFACTURE

FACTORY & YARD

1. Time-tested technology, conforming to quality standards shall be used
2. QA/QC processes at various points throughout the entire process shall be such as to mitigate product defects from reaching the field.
3. All materials shall be re-inspected for QA prior to loading into containers for shipment.
4. Provision for 3rd party inspection certificates shall be available for high demanding Clients

ENGINEERING SERVICES

1. Full-Service design & engineering services shall be provided by the manufacturer.
2. Designs shall be carried out by competent professionals and shall be duly proof checked by an independent agency
3. Along with engineering designs of Superstructure, full installation drawings shall be provided with all engineering packages.
4. I materials shall be re-inspected

ON-SITE TECHNICAL SUPPORT

1. Dedicated on-site field services shall be a part of the manufacturer's scope of services.
2. Field Service Representatives (FSR's) shall oversee the installation, working with the Client's assembly crew.
3. FSR's shall be competent engineers with experience in erection and assembly. They shall be present at all times of the build and shall remain on-site until the bridge is fully installed & certifies that the bridge is built as per design intent.

MODULAR PRE-ENGINEERED BRIDGE SYSTEMS

For Permanent, Emergency and Temporary Applications



CONTENTS :

1. **MODULAR BRIDGES – History, Advantages & Application**
2. **SYSTEM DETAILS & BRIDGE COMPONENTS**
3. **MANUFACTURING – Fabrication & Quality Control**
4. **CONCLUSION**

CONCLUSION



- 1. Modular bridges play a vital role in the immediate restoration of rail/road communication and in developing connectivity to forward areas in new road construction.**
- 2. Modular Bridges are also very useful as permanent bridges, in remote areas where conventional bridging solutions are not easy due to problems of access, manpower to execute, supervise and maintain.**

MODULAR PRE-ENGINEERED BRIDGE SYSTEMS

For Permanent, Emergency and Temporary Applications



Thank You

For Patience